

Agilent PNA Microwave Network Analyzers

Application Note 1408-1

Mixer Transmission Measurements Using The Frequency Converter Application

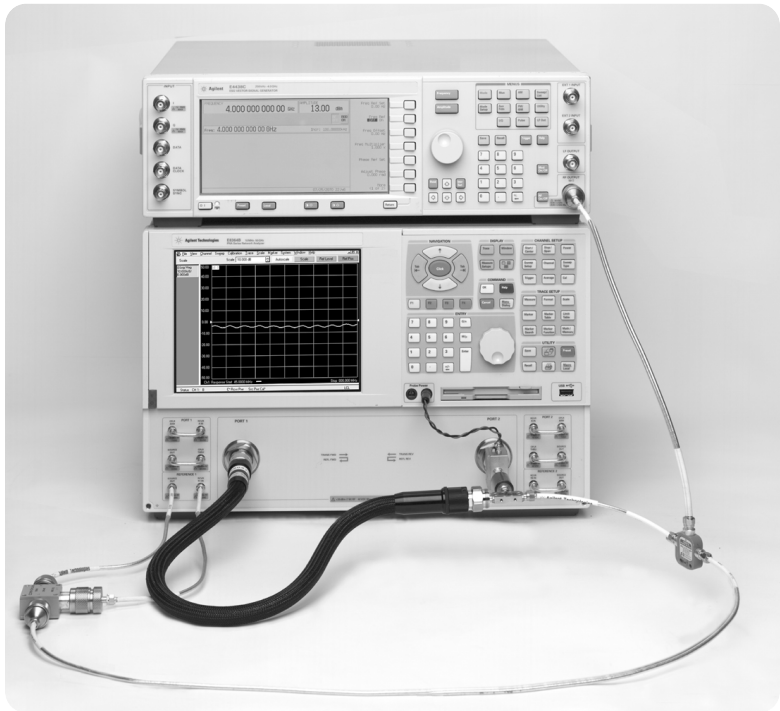

Agilent Technologies

Introduction

Frequency-converting devices are one of the fundamental components in every RF or microwave transceiver chain. These key components present unique measurement challenges because they exhibit both desired and undesired linear and non-linear behavior. There are several measurements needed to fully characterize frequency-converting devices [1].

- Transmission measurements include conversion loss or gain, group delay, derivation from linear phase, and port to port isolation.
- Reflection measurements include return loss and VSWR.
- Measurements that characterize the distortion added by the conversion process include, intermodulation distortion, conversion compression, and undesired mixing products.

Due to the nature of the required measurements, a stimulus-response ratioed measurement technique, such as S-parameter analysis, is ideal for most of the above measurements. Unfortunately, since these components have different input and output frequencies traditional S-parameter and network analysis techniques used for linear devices are not valid.

This application note describes how transmission measurements, using the frequency converter application available on the microwave PNA Series of network analyzers, can be performed. The application firmware automates the measurement process, making it possible for users without extensive knowledge of mixer measurements to set up, calibrate, and characterize devices quickly and accurately. A radio receiving system requires that the mixers within it have well-controlled amplitude, phase, and group-delay responses. The application includes advanced vector error-corrected calibration choices that enable accurate conversion loss, phase, and group delay measurements.

Vector Network Analyzers Measure Frequency Converters

Vector network analyzers are an important measurement tool for characterizing the magnitude, phase, group delay, impedance, linearity, and isolation performance of high-frequency components [2]. To accomplish this, a network analyzer provides a stimulus source, signal-separation devices, receivers for signal detection, display/processing circuitry and algorithms for reviewing results. The source is usually a built-in phase-locked (synthesized) voltage-controlled oscillator. Signal-separation hardware allows a portion of the incident signal to provide a reference for ratio measurements. One of the key advantages of using a vector network analyzer (VNA) for component measurements is its ability to characterize error signals that will be common in the setup for all measurements through a process called calibration. After calibration, the VNA removes the error signals from measurement results through a mathematical error correction process. During calibration, a series of reflection and transmission measurements are made of calibration standards that have known responses. Through a series of calculations the deviation from the known response and the measured response is determined. The difference can be attributed to a variety of systematic error signals [2]. Once these errors are known they can be removed in real-time during the measurement through error correction.

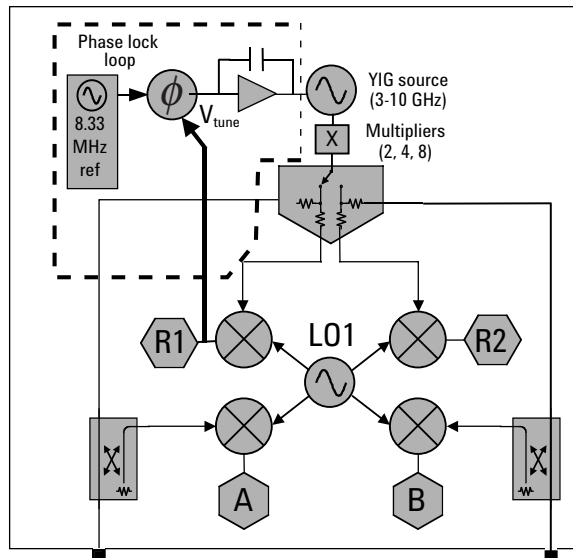

Figure 1. Simplified microwave PNA block diagram. Receivers phase locked to stimulus frequency.

The hardware architecture of the PNA Series network analyzer as shown in Figure 1 uses narrow-band mixer-based receivers. In this arrangement the measurement receivers, A and B, and the reference receivers R1 and R2 are phase locked and sweep in frequency with the source stimulus. In other words, they are tuned to receive a narrow frequency range centered at the source stimulus frequency. This is done to reduce the noise floor of the analyzer. Such techniques produce an exceptionally high dynamic range measurement. However, since the output is different from the input frequency for frequency converting devices, this tuned-receiver technique needs to be modified. To make these measurements possible the receivers must be independently tuned to a fixed offset from the stimulus. This technique is referred to as frequency-offset and is an option on many vector network analyzers.

This requires additional phase locking hardware and firmware control. Figure 2 shows the PNA block diagram with this additional frequency-offset hardware. Traditional techniques used for calibration and error correction are not valid with frequency-offset hardware changes because the error terms cannot be maintained in a constant phase relation. A modified frequency-offset error model is needed to describe the interactions of error signals in this environment. The derivation of this error model and supporting flow graphs are further described in Appendix A.

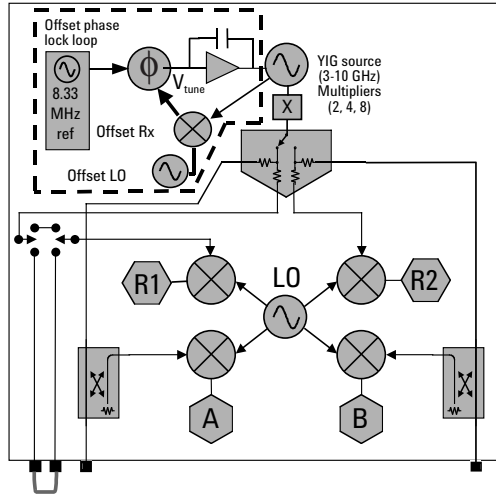

Figure 2. Simplified Microwave PNA block diagram with frequency-offset mode. Receivers independently tuned to an offset frequency of the stimulus.

The frequency converter application is an option offered with the microwave PNA Series network analyzers and is designed to address both the calibration and measurement difficulties in traditional frequency-offset measurements. Figure 3 shows the main screen used to configure the start and stop frequencies over which the device needs to be measured. The local oscillator (LO) frequency is entered and the application calculates the frequency range of the output, sets the measurement receivers to the correct offset, and sets an external source LO to its correct frequency and power level. This automated feature saves time and reduces the possibility of user error.

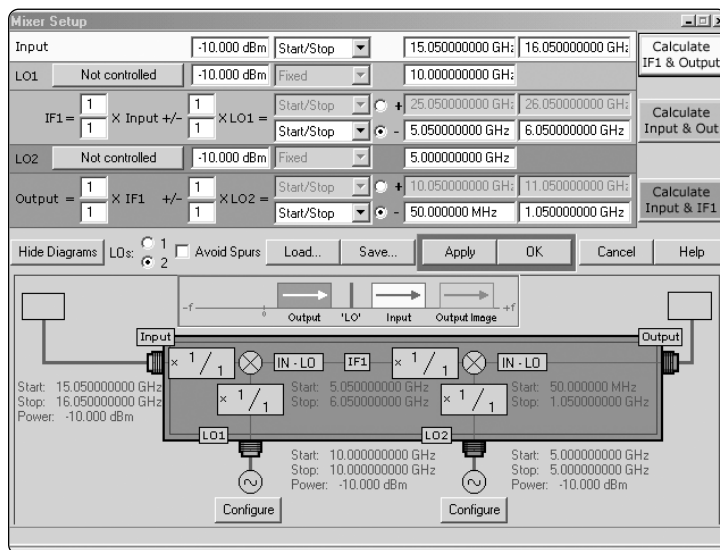

Figure 3. The application mixer setup window allows the user to enter all values in a single screen, guided by the instrument, to ensure compliance with acceptable limits.

When configuring conversion measurements using the PNA it is important to specify the type of measurement that should be made. There are two types – magnitude or magnitude and phase. Each measurement type has a unique setup and calibration method. It is important to note that S-parameters are not valid to describe a converter’s transmission response. S-parameters are defined for linear ratios; a new designation that indicates frequency conversion is needed. The C-parameter is introduced to indicate the incident signal is at a different frequency than the response. If a magnitude only measurement is required a scalar conversion (SC_{21} or SC_{12}) trace is set up. Figure 4 shows the selection dialog used to indicate this choice. When phase measurements, including group delay, are required a vector conversion (VC_{21}) trace is set up. This is the complex ratio of the magnitude and phase response. Each measurement trace type utilizes a unique calibration method that maximizes accuracy with the simplest calibration and setup. The application automatically guides the user step by step through the appropriate calibration.

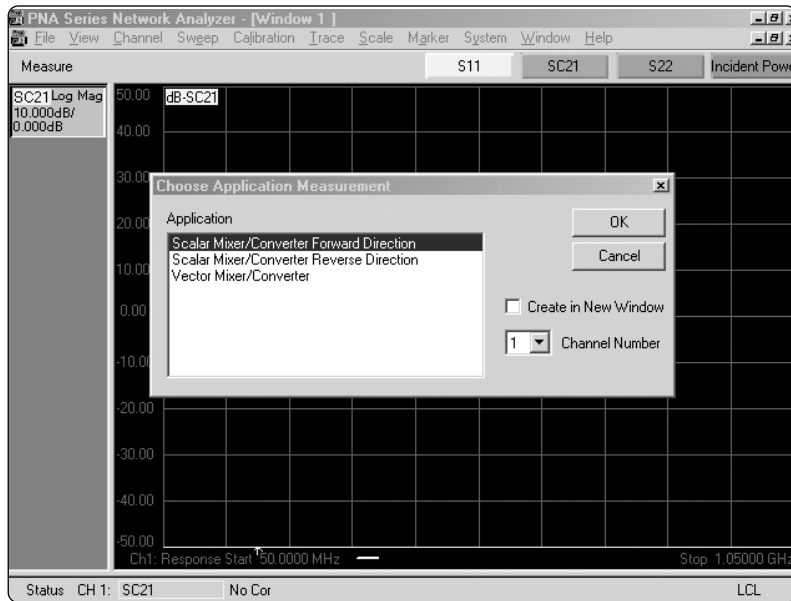

Figure 4. The trace setup dialogue guides users in setting up a trace.

Calibration and Error Correction

The frequency converter application implements vector-error correction techniques unique to frequency-offset measurements. This provides a level of accuracy that can be equal to the traditional 2-port, 12-term VNA calibration for linear devices. The key to these techniques is the derivation of an error model that accurately describes the interaction of error signals at the different frequencies in the system. This model starts with traditional 12-term model [3] and separates it into two halves. One part describes the input side error signals and the other, the output side error signals. The complete error model and flow graph can be found in Appendix A. The key to making this frequency-offset model work is bridging the gap between the two halves. The most significant error signals that affect most transmission measurements are the mismatch errors between the test set and the device under test. This mismatch error at the input is known as the source match error (E_{SF}) and can be isolated to the input half of the frequency-offset error model. Similarly, the mismatch at the output is isolated to the output half of the error model and is called the load match error (E_{LF}). The one term that cannot be completely isolated to only one half of the model is the transmission tracking error term (E_{TF}). A portion is a function of the source (E_{STF}) side interaction and another is a function of the receiver (E_{RTF}) side interactions. When these two contributors are combined, the complete error term (E_{TF}) is determined. Finding an accurate way of characterizing this is the breakthrough that allows frequency-offset error correction to be possible. For each of the two conversion measurements, SC_{21} and VC_{21} , this error term is characterized differently. The SC_{21} calibration method is the simpler of the two methods to perform. Figure 5 shows the configuration dialog for this calibration. This two-step calibration requires mechanical or electronic calibration standards and a power meter.

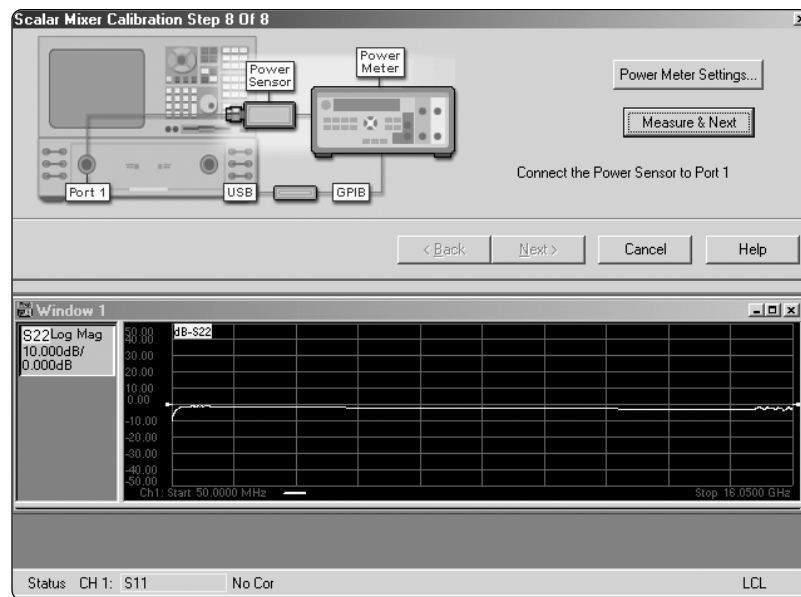

Figure 5. Step 2 of the scalar-mixer calibration uses a power meter to correct for the frequency response difference between the reference and measurement paths.

Scalar-Mixer Calibration [4]

The first step in the scalar-mixer calibration process is to perform a 2-port, 12-term calibration over the input and output frequency range of the device under test. The application prompts for the appropriate standards to be connected to the correct ports allowing measurements to be taken at both frequencies with a single connection. This is very important if mechanical standards are used because it greatly reduces the number of connections required. Electronic calibration is recommended because it is a significant time saver. The analyzer controls changes in the preprogrammed impedance states of the electronic calibration module to perform all required measurements with a single connection. The complete calibration yields 12 error terms at both the input stimulus and output response frequencies. All the error terms needed to apply the error model have been determined except the special frequency-offset E_{TF} .

The second step uses a power meter to determine the frequency response difference between the reference and the measurement signal paths. By definition this is E_{TF} . The impedance of the power sensor is measured to determine reflections at the sensor. This is used to correct for mismatch of the power sensor itself when making power measurements. This match-corrected power calibration is more accurate than traditional methods because of this correction factor. The power detected at the sensor is compared to that detected at the network analyzer reference receiver. The ratio becomes a correction factor and the E_{TF} calculated by the equations found in Figure 14. These calculations are explained further in Appendix B.

The SC_{21} measurement produces an offset-frequency-ratio measurement, the ratio of power levels at different frequencies. Since the reference is at the input frequency and the response at the output frequency their phases cannot be compared and thus this technique is only valid for scalar measurements. Figure 6 shows two measurements made on a two-stage down converter that includes filters and isolations with RF input power of -20 dBm. The RF input sweeps from 9.4 - 10.4 GHz and down converted to a first IF of 3.4 - 4.4 GHz. With a second LO of 3 GHz the signal is down converted again to 400 - 1.4 GHz, both sweeps use 2001 measurement points, and an IF bandwidth of 1000 Hz. Two Agilent PSG signal generators were used as the LOs with +10 dBm input to the mixer. The figure shows 4 traces. One pair shows the full 1 GHz bandwidth, which included the reject band of the input filter, and the other pair narrows the span to only the passband and increases the scale to 2 dB per division. This displays more clearly the 0.5 dB of error ripple that is present in the upper passband of the uncorrected measurement. In addition to removing the 2 dB cable loss effects from the measurement, the scalar-mixer calibration also removes these error signals from affecting measurement accuracy.

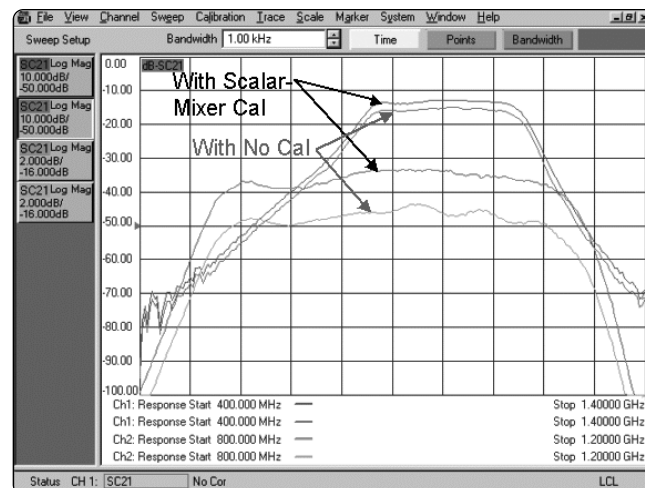

Figure 6. Measurement traces show the difference between corrected and uncorrected conversion loss results.

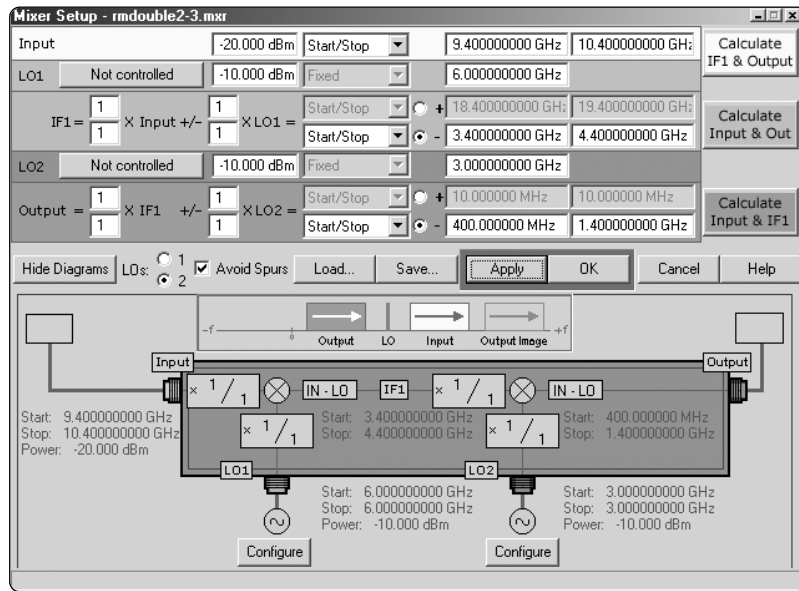

Figure 7. Setup dialog corresponding to measurement shown in Figure 6

Figure 7 shows the PNA application screen that is used to set up this measurement. Converters with internal LO can be measured easily with this method provided the LO frequency is known to within at least one half of the measurement's IF bandwidth and the frequency is stable over time. This is required so the PNA can accurately tune its receivers to the correct frequency to detect the conversion product.

Vector-Mixer Calibration [5]

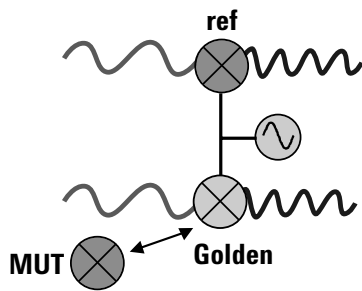

Figure 8. A golden mixer is one method used to normalize a test system and perform relative measurements.

Phase measurements are more complex and require a different calibration and measurement approach than previously covered. Measurements of phase require a reference signal at the same frequency. In linear measurements, the stimulus signal is coupled from the transmission path and used as the reference to which the response is ratioed. In the case of frequency-offset, the reference must undergo the same frequency conversion as the mixer-under-test in order for it to be used as a valid reference. The problem is that this frequency conversion should not have an effect, other than shifting frequency, on the reference signal. Many high performance network analyzers give access to the reference path through external jumpers. With these jumpers, a mixer can be placed in the reference path to provide this converted reference. One requirement for creating a reference is that it needs to be synchronous with the mixer-under-test. When the phase of the reference LO and mixer-under-test LO maintain a constant phase relationship they are said to be synchronous. For more information on synchronous conversion see Appendix C. The reference mixer has an unknown conversion loss and phase response. One popular approach to removing the reference mixer response is normalizing the test system using a golden mixer. Figure 8 illustrates how a golden mixer is placed in a parallel path to the reference mixer. After the normalization is complete the mixer-under-test is placed in the measurement path. In this case, instead of seeing the group delay of the one mixer, only the group delay delta between the golden and mixer-under-test is seen.

The vector-mixer calibration technique is a unique calibration method that eliminates the need to normalize the system and perform relative measurements. The vector-mixer calibrated measurement, shown in Figure 9, is produced using the test configuration found in Figure 10. Through a three-step calibration process it is able to remove the response of the reference path including the reference mixer.

- The first step is the same as the scalar-mixer calibration. It is a 2-port, 12-term calibration over the input and output frequencies that determines all the error terms except E_{TF} .
- The second step is to characterize a calibration mixer that is used as a through calibration standard for the remaining calibration process. One advantage of the PNA application is that it can store calibration mixer files so this step does not need to be performed during every calibration sequence. Once a mixer is characterized over its specific frequency range, LO and RF power level, it can be used during a new calibration. This characterization step involves a series of reflection measurements on calibration standards similar to a 1-port calibration. From these measurements the complex input match, output match, and conversion loss can be calculated. These are needed to use the mixer as a characterized through. The only assumption to use this technique is that the calibration mixer is reciprocal. A complete explanation of how this mixer is characterized is found in Appendix C.
- Step three removes the response of the reference path of the test system including cables, adapters and the reference mixer. As with the 12-term model, the difference between the measurement and reference paths is corrected in the transmission tracking error term (E_{TF}); the same is true here. Appendix C explains this process further. Correcting for the input and output match, the actual conversion is determined in step two and is compared to the conversion response measured. The measured response is a ratio of the conversion of the calibration mixer and the reference mixer responses. Once E_{TF} is calculated the frequency-offset error model can be used and will remove the systematic errors as well as the response of the reference mixer from the measurements.

The principle advantage of using either calibration method is that it brings vector-error correction to the domain of frequency-translating measurements. This sets it apart from all other techniques that simply seek to minimize the large mismatch reflection that cause systematic errors with the use of attenuators. As in linear vector-error correction, frequency-offset error correction mathematically removes these systematic errors in the transmission from the measurement.

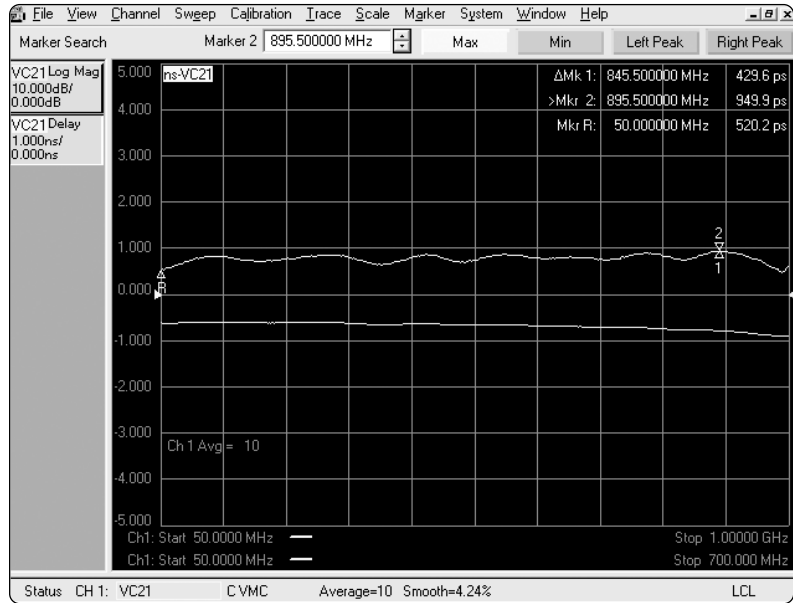

Figure 9. Group delay and conversion loss measurements made using the vector-mixer calibration.

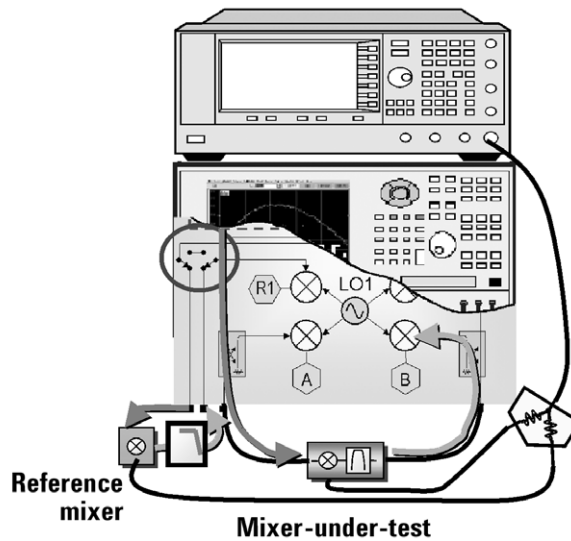

Figure 10. Vector-mixer calibration requires a reference mixer to provide a phase reference.

Selecting Calibration and Reference Mixers

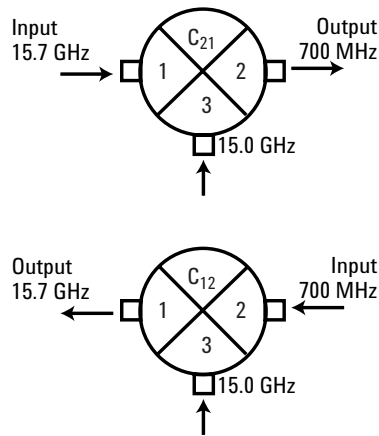

Figure 11. Mixer reciprocity is demonstrated when their up conversion (C_{21}) and down conversion (C_{12}) responses are equal.

The calibration mixer that is used as a characterized through has few requirements. The characterization process works on the principle of reflection measurements. The mixer is assumed to be reciprocal; meaning that its magnitude and phase conversion response is equal for both up conversion and down conversions. Figure 11 illustrates the principle of mixer reciprocity. When used as a down converter a high frequency input is presented at port 1 and a low frequency signal is output at port 2. The measured result is C_{21} . To determine reciprocity the corresponding C_{12} up conversion response must be measured. The same low frequency signal is input at port 2 and the converted high frequency signal measured at the output port 1. This is significant because the calibration mixer measurement will always be the composite of the up conversion and down conversion responses, and must be able to convert over the full range of the mixer-under-test. The reflection responses must be measured at an input power level that produces a linear response for all the reflection measurements. Additionally, an IF filter is required at the mixer output. This is used to separate the upper and lower conversion products. Either product can be used to characterize the mixer, however, one needs to be selected and the other filtered for the procedure to work correctly. The mixer and filter combination is the characterized through standard used in the calibration processes. For a complete guide to selecting a calibration mixer, reference the Agilent PNA Network Analyzer Application Note Series 1408.

Selecting a reference mixer is much easier. It does not need to be reciprocal and does not have to match the calibration mixer or the mixer-under-test in performance. It only needs to cover the same frequency range as the mixer-under-test. In general, it is valuable to select a reference mixer that can be used with a variety of different setups. For example, a broadband mixer can be used in place of several narrow-band alternatives.

Summary

There are many challenges associated with making measurements on non-linear frequency conversion devices. Complex measurement configurations, unwanted error signals, complicated instrument menu structures, and setup can all add to frustrations. Inaccurate or incomplete measurement results do not meet the strenuous design requirements of high performance radio transceivers. The microwave PNA Series network analyzer's frequency converter application addresses all of these issues by: simplifying complex instrument setups with its graphical user interface and calibration wizards, correcting for the systematic error signals in the transmission path through advanced vector correction techniques, and simplifying device setups by reducing the need for multiple golden mixers and attenuators. The PNA makes converter measurements fast and easy, while giving you more confidence in the results.

Appendix A: Frequency-Offset Error Model and Flow Graphs

The frequency-offset error can be described by the flow graph in Figure 12. From the flow graph it can be seen that the model is divided in two halves; the input and output halves. By conceptualizing the error model in two halves, each error term can be isolated to one half of the model at the frequency in which it is generated. The majority of the signals will only affect measurements by causing errors at the same frequency. The two error signals that are a function of both halves of the flow graph are the isolation (E_{XF}) and transmission tracking (E_{TF}). E_{XF} is set to zero because it will not be detected due to the frequency change. E_{TF} must be split into the errors associated with the source side at the input frequencies and the receiver side at the output frequencies. Their notations are E_{STF} and E_{RTF} , respectively. As previously discussed, calculating the frequency translating, E_{TF} , in these two parts is the key to using vector-error correction during frequency-offset measurements. The scalar-mixer calibration and the vector-mixer calibration approaches its calculation using different techniques explained below.

In the traditional 2-port, 12-term error model it makes sense to simplify the reflection tracking error to a single term E_{RF} . This is done by setting the incident frequency response to 1 and representing the error in the reflected response term (E_{RF}) as shown in Figure 13. As a result of the E_{TF} being represented in two parts in the frequency-offset model, the reflection tracking also needs to be represented in two parts. The incident reflection tracking response is denoted as E_{STF} and the reflection response as E_{SRF} . When they are multiplied together they are equivalent to the traditional reflection tracking term.

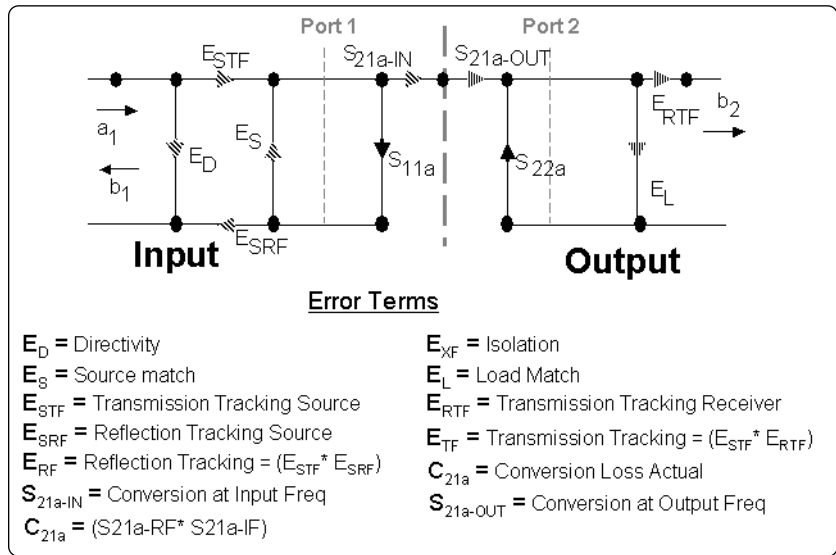

Figure 12. Frequency-offset error model flow graph.

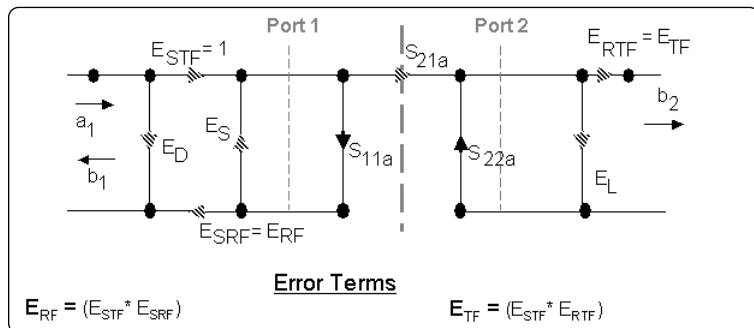

Figure 13. Linear 2-port error model.

Appendix B: Scalar-mixer Calibration Theory

The second step in the scalar-mixer calibration is to perform a match-corrected power-meter calibration. A match-corrected power-meter calibration differs from a traditional power-meter calibration in that the match of the power sensor is measured and is used to calculate the true incident power. The calculated mismatch between the power-sensor match and the corrected-source match of the PNA is used to correct the raw power values read by the sensor. The scalar-mixer calibration calculates E_{TF} by measuring the frequency response error of the source E_{SRF} directly from the power meter reading. It does this for both the input and output frequencies. The result at the output frequency is divided by the output frequency E_{TF} calculated in the 12-term model. This calculation yields the E_{RTF} at the output frequency. E_{STF} and E_{RTF} can be multiplied together and the result is a scalar frequency-offset E_{TF} . Since it is the multiplication of two power measurements the result is a scalar term. This is shown in Figure 14.

$$E_{STF} = \frac{\sqrt{P_{\text{sensor}} |1 - E_S \Gamma_{\text{sensor}}|}}{|R1|} \quad E_{RTF} = \frac{E_{TF}}{\frac{\sqrt{P_{\text{sensor}} |1 - E_S \Gamma_{\text{sensor}}|}}{|R1|}}$$

$$E_{TF} = E_{STF} * E_{RTF}$$

Figure 14. Scalar-mixer calibration and matched-power-meter calibration equations to calculate frequency-offset E_{TF} .

Appendix C: Calibration Mixer Characterization Theory

The vector-mixer calibration has two key technological innovations. The first is the method in which a mixer is used as a characterized frequency-translating through calibration standard. This has long been the limitation that precluded the widely accepted 2-port error model from working for frequency-translation measurements. The second innovation is how this standard is characterized. The system calibration is of course directly related to the accuracy with which the standard's response is known.

The characterization process uses a self-reverting reflection measurement technique. To measure phase, a phase reference must be used. One method to create a phase reference is to use a second mixer to reconvert the output of the first mixer back to its input frequency. When this is done in series it is known as the up/down conversion method. Then a transmission ratio measurement can be made at the same frequency. The new PNA method eliminates the need for the second mixer, and uses a single mixer and IF filter combination to both convert and reconvert; thus creating its own reference signal. Using a 1-port calibration and a series of 1-port reflection measurements as shown in Figure 15 the complex input match, output match, and conversion loss of the mixer standard are computed. Now the mixer is able to be used as a characterized through to complete the calibration process.

A down converter is used as an example in Figure 15 to show the sources of the reflections and their composite measured response when a variety of impedance standards are placed on the output of the filter. A portion of the response is not affected by the reflection standard because it is either not converted by the mixer or is rejected by the IF filter. This can be isolated by measuring the response when a load is placed on the output of the IF filter and is shown in Figure 15c. By definition this is the input match of the mixer/filter standard as shown in Figure 16a.

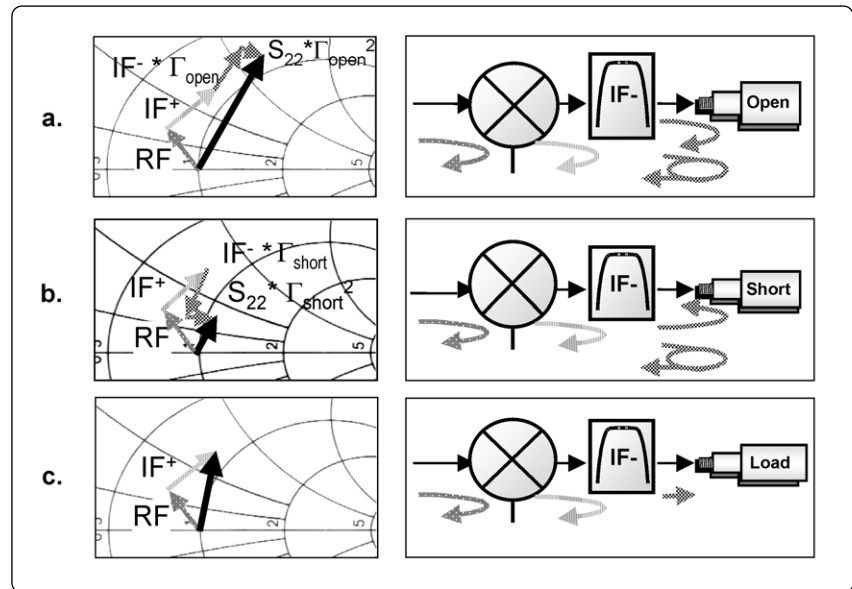

Figure 15a. Open response, b. Short response, c. Load response.

Figures 15c and 15b show the response when an open and short are placed on the output of the mixer/ filter, respectively. The measured reflection phasors of the open and short will have the same magnitude but will be 180° different in phase. Figure 16c illustrates that by adding the negative of the short response to the open response and subtracting the common load response twice, the round trip transmission response ($C_{21} * C_{12}$) can be isolated. With some further calculations the one-way complex conversion loss (C_{21}) can be accurately determined assuming that $C_{21} = C_{12}$. Finally, the output match is determined by repeating the last calculation and reversing the sign of the short response. This is shown in Figure 16b.

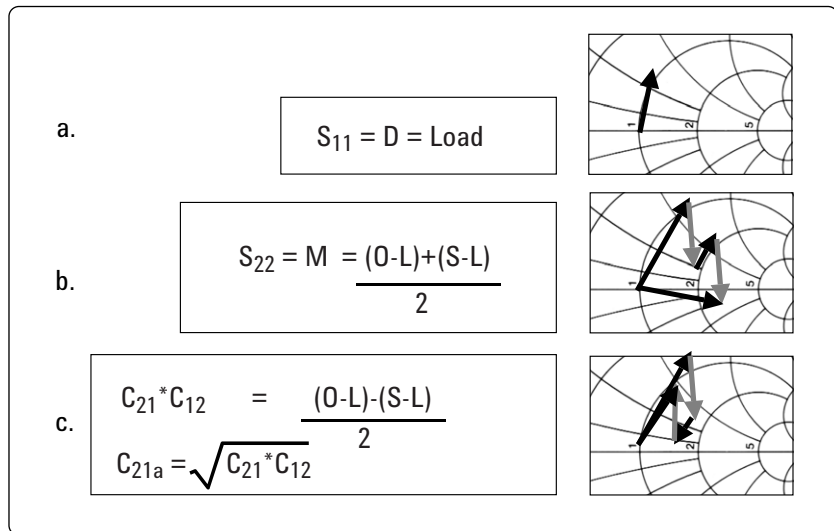

Figure 16a. Calibration mixer input match, b. Calibration mixer output match, c. Calibration mixer conversion loss.

Once the characterization is complete it is then used to calibrate the network analyzer through another innovative process. As stated previously, a reference mixer needs to be added to the PNA's reference path to create a translated reference signal to which measurement ratios are performed. This is done through external jumpers that gives access to the reference path. The effects of adding a reference mixer to the path are removed when the characterized mixer/filter is used to perform the through portion of the calibrating process. By using the equation in Figure 17 the frequency-offset transmission tracking error term can be calculated.

$$E_{TF} = \frac{C_{21m}}{C_{21a}} (1 - M * E_{LF} - D * E_{SF} - E_{SF} * C_{21a} * C_{12a} * E_{LF} + E_{SF} * M * D * E_{LF})$$

$D = \text{Calibration mixer/ filter } S_{11}$
 $M = \text{Calibration mixer/ filter } S_{22}$
 $C_{21a} = \text{Calibration mixer/ filter actual down conversion loss}$
 $C_{12a} = \text{Calibration mixer/ filter actual up conversion loss}$
 $C_{21m} = \text{Calibration mixer/ filter measured conversion loss}$

Figure 17. Error equation to calculate frequency-offset transmission tracking error term for the vector mixer calibration.

References

- [1] *Improved Network Analyzer Measurements of Frequency-translating Devices*, Agilent Application Note 1287-7, literature number 5966-3318E
- [2] *Exploring the Architectures of Network Analyzers*, Agilent Application Note 1287-2, literature number 5965-7708E
- [3] *Applying Error Correction to Network Analyzer Measurements*, Agilent Application Note 1287-3, literature number 5965-7709E
- [4] *Comparison of Mixer Characterization using New Vector Characterization Techniques*, by Joel Dunsmore, 32nd European Microwave Conference Proceedings, Vol 1, September 24, 2002, pp 163-166 and Agilent white paper, literature number 5988-7827EN
- [5] *Novel Method for Vector Mixer Characterization and Mixer Test System Vector Error Correction*, by Joel Dunsmore, 2002 IEEE_MTT-S International Microwave Symposium Digest, Vol 3, pp 1833-1836 and Agilent white paper, literature number 5988-7826EN

Web Resources

For additional information about the Agilent PNA Series visit:

www.agilent.com/find/pna

For additional information about the Agilent electronic calibration (ECal) visit:

www.agilent.com/find/ecal



Agilent Email Updates

www.agilent.com/find/emailupdates

Get the latest information on the products and applications you select.

Agilent Technologies' Test and Measurement Support, Services, and Assistance

Agilent Technologies aims to maximize the value you receive, while minimizing your risk and problems. We strive to ensure that you get the test and measurement capabilities you paid for and obtain the support you need. Our extensive support resources and services can help you choose the right Agilent products for your applications and apply them successfully. Every instrument and system we sell has a global warranty. Support is available for at least five years beyond the production life of the product. Two concepts underlie Agilent's overall support policy: "Our Promise" and "Your Advantage."

Our Promise

Our Promise means your Agilent test and measurement equipment will meet its advertised performance and functionality. When you are choosing new equipment, we will help you with product information, including realistic performance specifications and practical recommendations from experienced test engineers. When you use Agilent equipment, we can verify that it works properly, help with product operation, and provide basic measurement assistance for the use of specified capabilities, at no extra cost upon request. Many self-help tools are available.

Your Advantage

Your Advantage means that Agilent offers a wide range of additional expert test and measurement services, which you can purchase according to your unique technical and business needs. Solve problems efficiently and gain a competitive edge by contracting with us for calibration, extra-cost upgrades, out-of-warranty repairs, and onsite education and training, as well as design, system integration, project management, and other professional engineering services. Experienced Agilent engineers and technicians worldwide can help you maximize your productivity, optimize the return on investment of your Agilent instruments and systems, and obtain dependable measurement accuracy for the life of those products.

Agilent T&M Software and Connectivity

Agilent's Test and Measurement software and connectivity products, solutions and developer network allows you to take time out of connecting your instruments to your computer with tools based on PC standards, so you can focus on your tasks, not on your connections. Visit www.agilent.com/find/connectivity for more information.

By internet, phone, or fax, get assistance with all your test & measurement needs

Phone or Fax

United States:
(tel) 800 452 4844

Canada:
(tel) 877 894 4414
(fax) 905 282 6495

China:
(tel) 800 810 0189
(fax) 800 820 2816

Europe:
(tel) (31 20) 547 2323
(fax) (31 20) 547 2390

Japan:
(tel) (81) 426 56 7832
(fax) (81) 426 56 7840

Korea:

(tel) (82 2) 2004 5004
(fax) (82 2) 2004 5115

Latin America:
(tel) (305) 269 7500
(fax) (305) 269 7599

Taiwan:
(tel) 0800 047 866
(fax) 0800 286 331

Other Asia Pacific Countries:
(tel) (65) 6375 8100
(fax) (65) 6836 0252

Email:
tm_asia@agilent.com

Online Assistance:

www.agilent.com/find/assist

Product specifications and descriptions in this document subject to change without notice.

© Agilent Technologies, Inc. 2003, 2004
Printed in USA, January 27, 2004
5988-8642EN



Agilent Technologies